

48" x 60" MANHOLE ASSEMBLY

36" & 48" DEPTHS



POLYMER CONCRETE

ARMORCAST PRODUCTS COMPANY

A6001447H

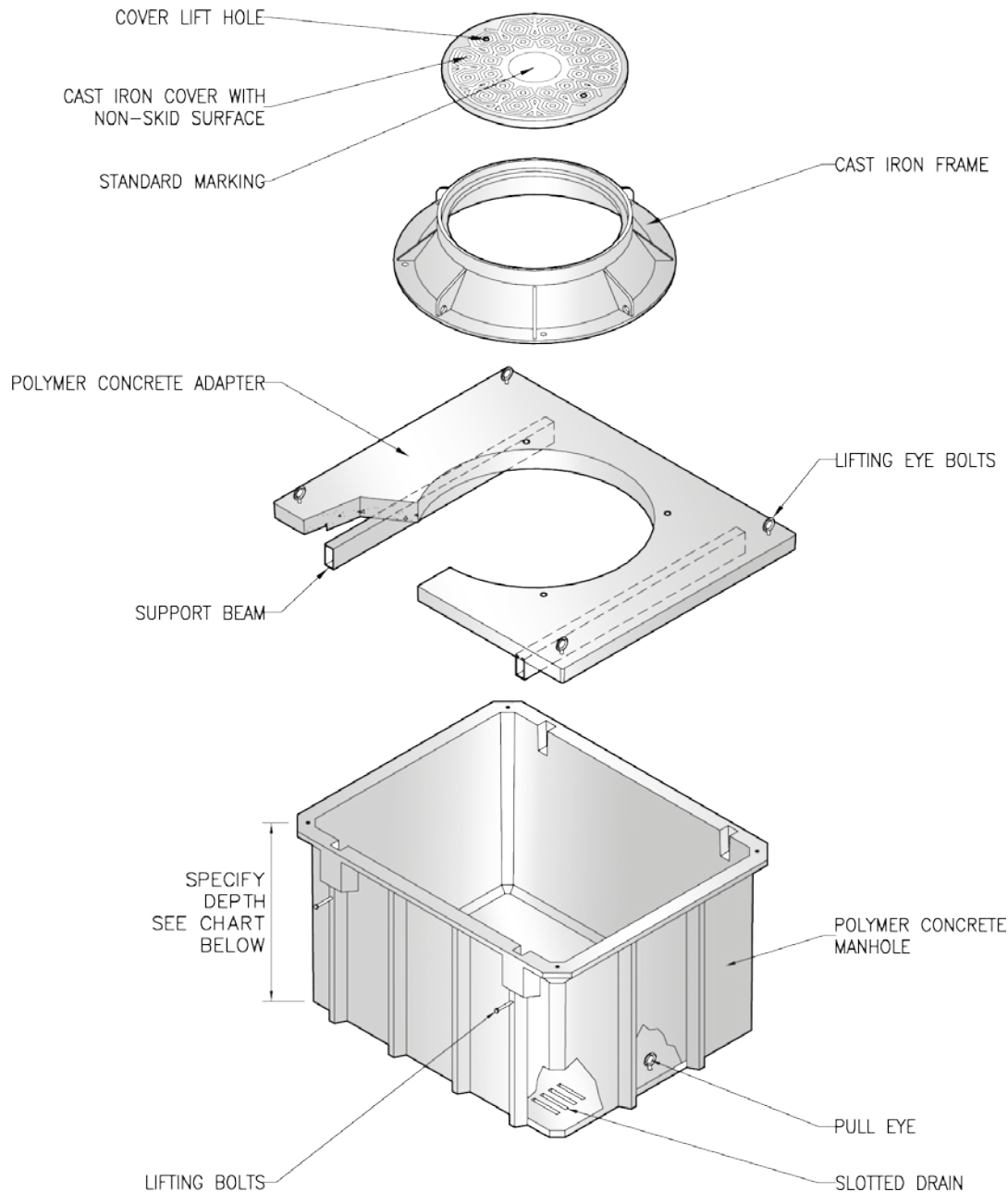

48"W x 60"L MANHOLE ASSEMBLY Specify Depth Below

DESCRIPTION	NOMINAL SIZE W x L x D	LOAD RATING	ANSI TIER	PART NUMBER	APPROX. WEIGHT	PALLET QTY.
Manhole & Cover Assembly	48" x 60" x 36"	H20	-	A6001447HTAP36B	1785 lbs.	1
Manhole & Cover Assembly	48" x 60" x 48"	H20	-	A6001447HTAP48B	1935 lbs.	1

- Solid Bottom and includes Cast Iron Ring & Cover
- For sizes not shown please contact Armorcast Products for more information.

www.armorcastprod.com

Tel: (818) 982-3600 Fax: (818) 982-7742



48" x 60" MANHOLE ASSEMBLY

STANDARD DIMENSIONS

ARMORCAST PRODUCTS COMPANY

POLYMER CONCRETE

A6001447H

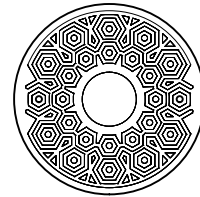
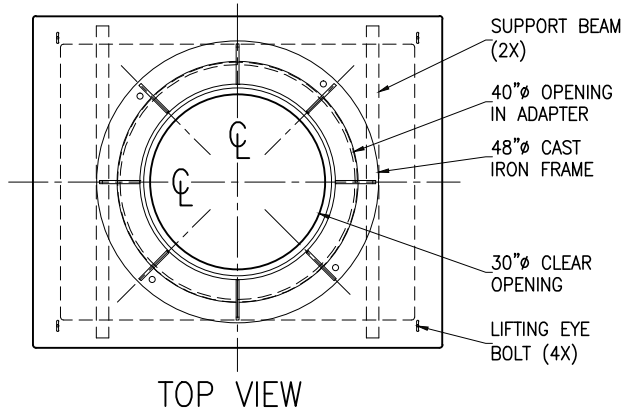

TOP VIEW
32" C.I. COVER

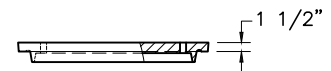

SECTION - C.I. COVER

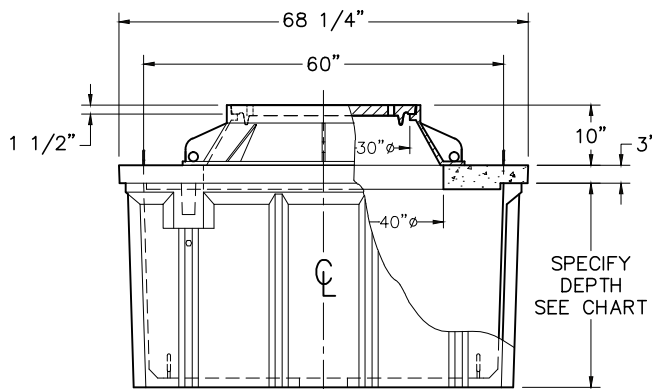

SIDE VIEW

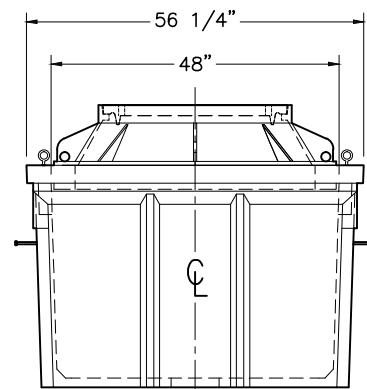

END VIEW

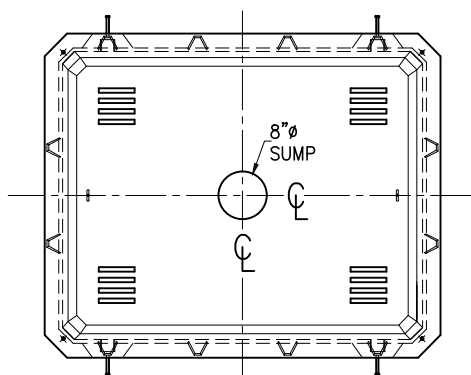

POLYMER CONCRETE MANHOLE
TOP VIEW

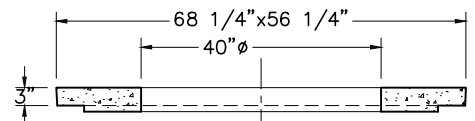

SECTION -
POLYMER CONCRETE ADAPTER

Armorcast Products Company reserves the right to update or discontinue product information at any time without notice.

www.armorcastprod.com

Tel: (818) 982-3600 Fax: (818) 982-7742

POLYMER CONCRETE
VAULTS & MANHOLE